

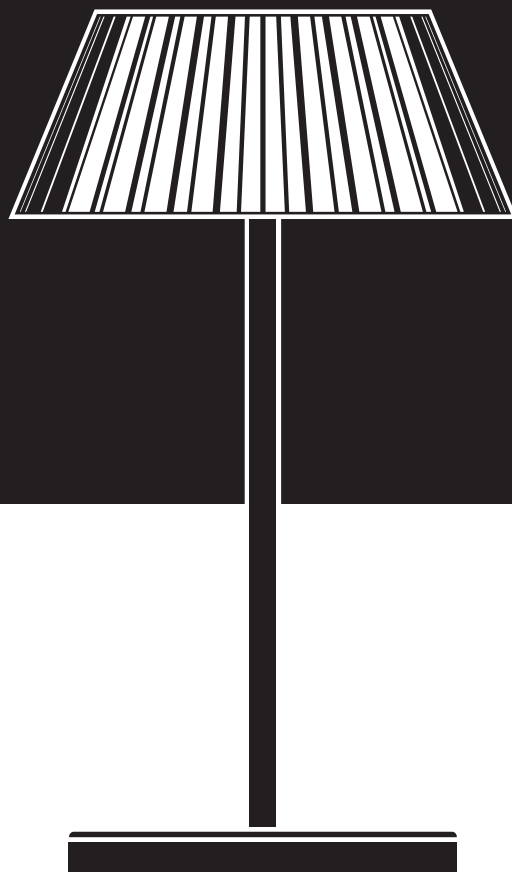

utopia

ARUBA

LED TABLE LAMP



Operating Instructions

ARUBA

LED TABLE LAMP

LED 2.7K - 3.3K switchable
2.3W - DC 5V - IP54

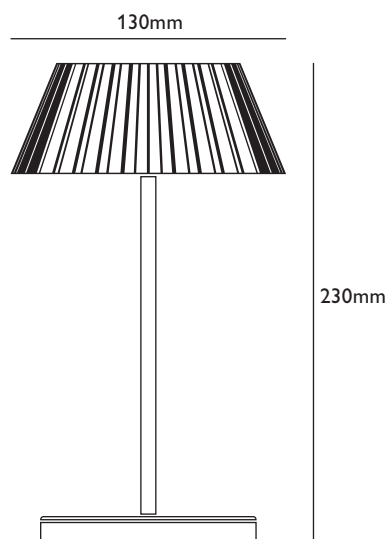

Product Description

Model Aruba	Application Rechargeable table light	Net Weight 875g	Dimensions 130 x 230mm	Inner Box 160 x 135 x 265mm	Outer Carton 335 x 285 x 360mm	Pcs/Ctn 6
Input Voltage DC5V	Power 2.3W	Safety Class CLASS III	Ingress Protection IP54	Beam Angle 120°	Light Source LED	Luminaire Flux 240 lm
Materials Die-cast aluminium alloy, polycarbonate diffuser						

How to use

This product is made exclusively for lighting purposes.

It must not be exposed to heavy mechanical loads or contamination. Please install and use only after thoroughly checking that it is undamaged. Any installation or maintenance must be carried out while the product is turned off. Any alterations to the product, tampering with the product, or failure to comply with the instructions may harm the product and make it hazardous. When fully assembled, the lamp (not including the charging base), reaches an IP54 rating making it suitable for outdoor use. When assembled fully and on top of the charging base it has an IP20 rating which means it is not suitable for outdoor use. All metal and plastic surfaces should be cleaned with a soft dry cloth. Utopia shall not be held liable for any damage caused due to its products being assembled or used in any manner that does not comply with these instructions.

Battery charger technical data

- Contact charging base : INPUT/OUTPUT 5Vdc -1A; cavo USB 1.2 Mt.
- Charger: INPUT AC100-240V 50/60Hz; OUTPUT 5Vdc -1A.
- This lamp may also be used when connected to the charging base.
- It is advised that only the original provided charging base is used. Alternatively, 1A max chargers can be used.

Important to know

- The lamps supporting surface should not exceed 15° of tilt or it will fall.
- To preserve the integrity of this battery, we recommend keeping the charging to 20% minimum to 80% maximum; if the lamp is not used regularly it is advised to regularly charge/discharge it.
- Your LED Cordless lamp is designed to provide reliable illumination, and on average, you can expect it to maintain 80% of its original battery capacity after approximately 300 full charge cycles.
- Please refer to local laws/guidance for proper disposal/recycling of the battery.

Table Lamp IP54

Contact Charging
Base IP20

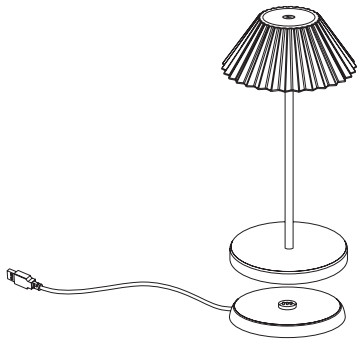

ON/OFF TOUCH SWITCH

Turn lamp on with one touch, twice to turn off

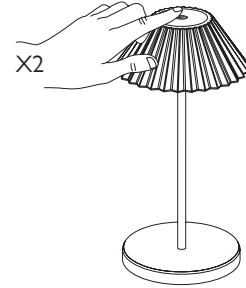
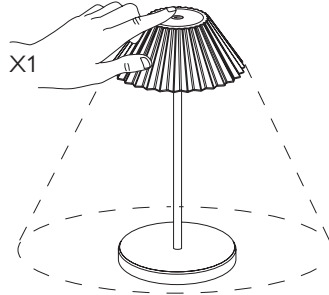

STEPLESS DIMMER

Press and Hold On/Off Switch

Only works when light is on.

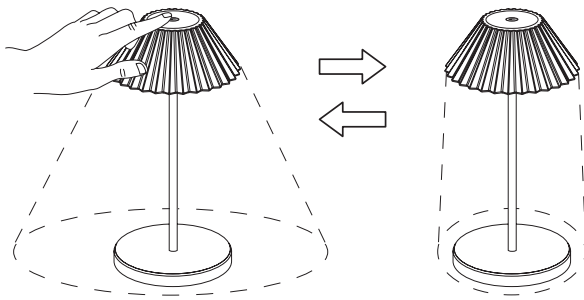

CCT SETTING

Short Press and Release On/Off Switch, Warm/Cool
White

Only works when light is on.

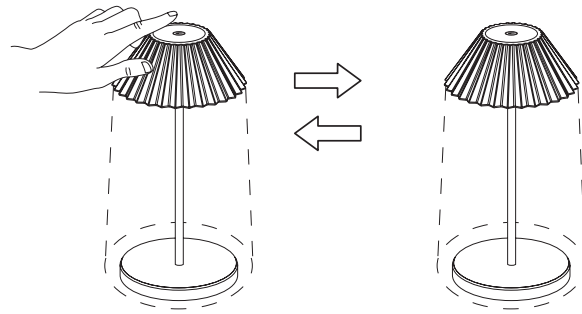

CHARGE

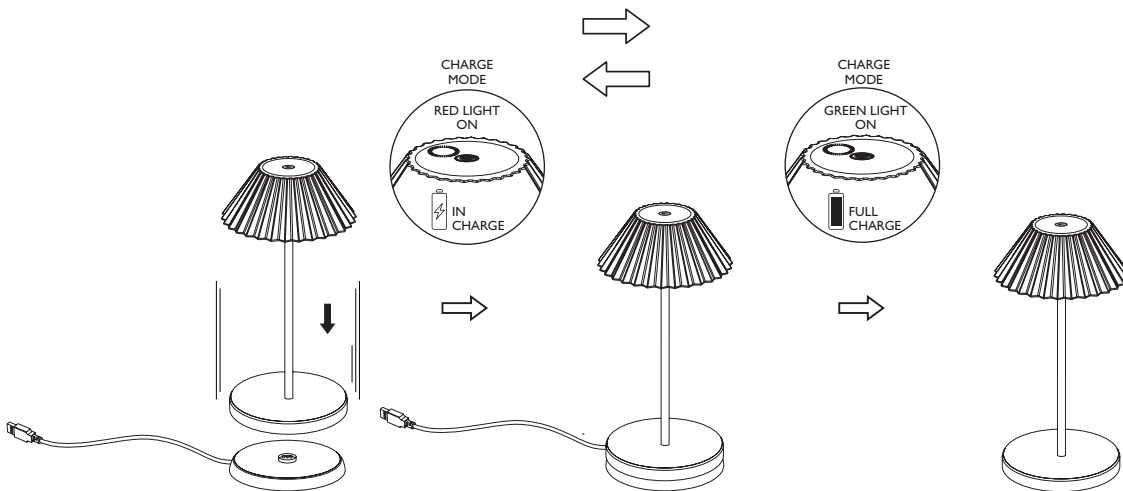

trenton

**Head Office &
Sydney Showroom**

4 Burrows Road South
St Peters NSW 2044
Phone +61 2 8571 9988
office@trenton.com.au

Melbourne Showroom

Level 1, Suite 1, 55 Walsh Street
West Melbourne VIC 3003
Phone +61 414 417 030
vicsales@trenton.com.au

Brisbane Showroom

54 Doggett Street
Newstead QLD 4006
Phone +61 7 3257 7100
qldsales@trenton.com.au

Brisbane Warehouse

Unit 1, 500 Green Road
Crestmead QLD 4132
Phone 1800 800 058
qldoffice@trenton.com.au

Perth Showroom

20 Aitken Way
Kewdale WA 6105
Phone +61 414 991 120
deanna@trenton.com.au

New Zealand

Phone +64 27 557 9440
joanne@trenton.co.nz